



Arbitrium

It is our choices, Harry, that show what we truly are, far more than our abilities.

-Professor Albus Dumbledore
(Harry Potter and the Chamber of Secrets)

Problem Statement:

Design an autonomous cum semi-autonomous (E.g. Bluetooth controlled) robot. Fully autonomous robots are allowed too.

When in the semi-autonomous mode, the bot should be able to move in the forward, right and left directions, stopping when required. The bots here are controlled by an external device.

When in the autonomous mode, the robot should be capable of following a black line on the white floor, a white line on the black floor, avoiding obstacles and identifying the colour of the obstacles placed in the front.

Game Play:

Year- 2089: There is a deep energy crisis on Earth. With the conventional sources exhausting and the renewable energy sources not much popular, the world seems to be endangered. In this hour, you find a time machine to take you back in time. Each time you cross a space-time warp, you go back by ten years. Crossing all the seven of the space-time warps, you are transported back to the year 2k19.

Now, it's time to make a choice. At each turn, let your bot choose the right path towards a brighter future. Let your bot "Redefine the Conventions" today to create a better tomorrow. The future of our dear planet Earth is in your hands now...

Preliminary round (Line following only):

The preliminary round starts in the year 2089. The humans are beginning to recognise the need of using renewable energy. Follow the path which guides you to the renewable energy sources.



- The bot starts from the “START” point and follows the line till the “END” point is reached. In the first half of the track, the bot follows a black line on the white floor and in the latter half, the bot follows a white line on a black floor.
- At each T junction, there are walls to assist the bot. (Please refer to the arena for further clarifications).
- Between the two halves of the track, there is an “H” junction. The floor of the “H” is the same colour as the line on each half of the track. This is the “CHECKPOINT”. On detecting the checkpoint, the bot blinks a bright LED twice, at a gap of half a second. When the checkpoint is detected, the wall in the front is removed and the bot proceeds further.

The preliminary round is to be completed by each of the teams in a maximum time of 300 seconds.

Final round:

Even after going for the renewable energy sources in the year 2089, you realise that very less can be done now. It is too late to save the planet. The only option left is to go back in time and aware the humans in 2k19. For that you find a zone of seven condensed space-time warps which will take you seventy years in past.

- The bot starts in the semi-autonomous mode from the “START” point. There are several cylindrical objects (space-time warps) placed in the bot’s path to the GATES. The **semi-autonomous** bot goes around each of the obstacles in a zig zag fashion and reaches the GATES. A fully autonomous bot is expected to do the same.
- At the gate, there are two laser beams in the bot’s path. One of them cuts the path from left to right while the other one cuts it from right to left. The laser beams blink alternately at a gap of one second. The bot crosses the laser beams, cutting one of them as it does so. If the first beam (Left to right) is cut, the gate to the “line follower track” opens. If the second beam (Right to left) is cut, the gate to the “wall avoider track” opens. Now you are transported back in time
- The Bluetooth controlled bot is then placed at the “START” of the track (to which the gates are opened) and then is switched to the **autonomous mode**.
- If the gate to the “wall follower track” opens when the laser beam is cut, the bot starts from the “START” point of the wall avoider track. The bot then, first goes through the wall follower track and then through the line follower track. The vice versa happens if the gate to the “line follower track” opens at the laser

beam, i.e. the bot first goes through the line follower track and then through the wall follower track. (Please refer to the arena image)

Now follow the path of smart energy sources to create a brighter future.

The Wall Follower:

- The bot detects each turn in the wall and turns as the wall turns, following the wall.

The line follower:

- The game play of the line follower is same as in the preliminary round.

Between the two tracks, the line follower and the obstacle avoider, there is an “H” junction. This is the “CHECKPOINT”. Here, the bot stops and blinks a bright LED twice, at an interval of half a second. When the Checkpoint is detected, the wall in the front is removed and the bot can move further.

The final round needs to be completed by each of the teams in a maximum time of 900 seconds.

Know your Arena:

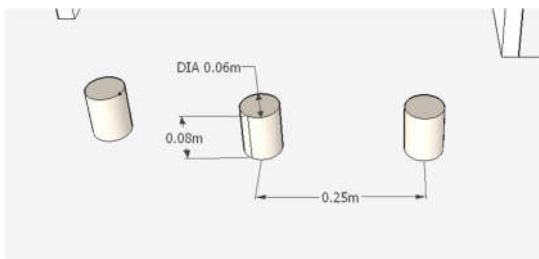

The diameter of the space-time warps in the semi-autonomous track is 6cm, their height is 8cm and the distance between the centres of the two cylindrical obstacles is 25cm.

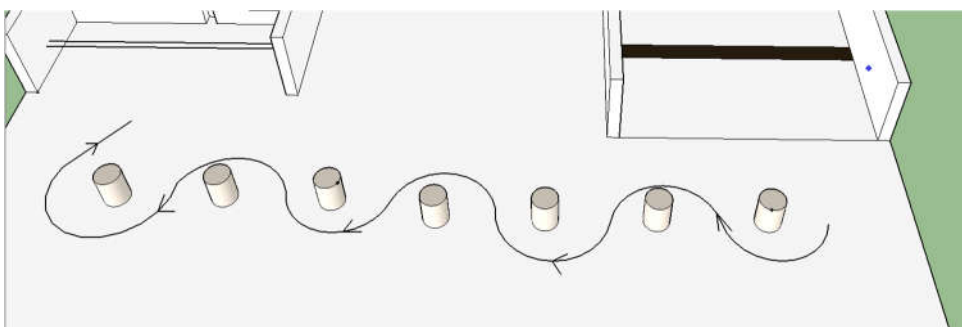

The rough path (the zig-zag fashion) to be followed by the bot in the semi-autonomous track.

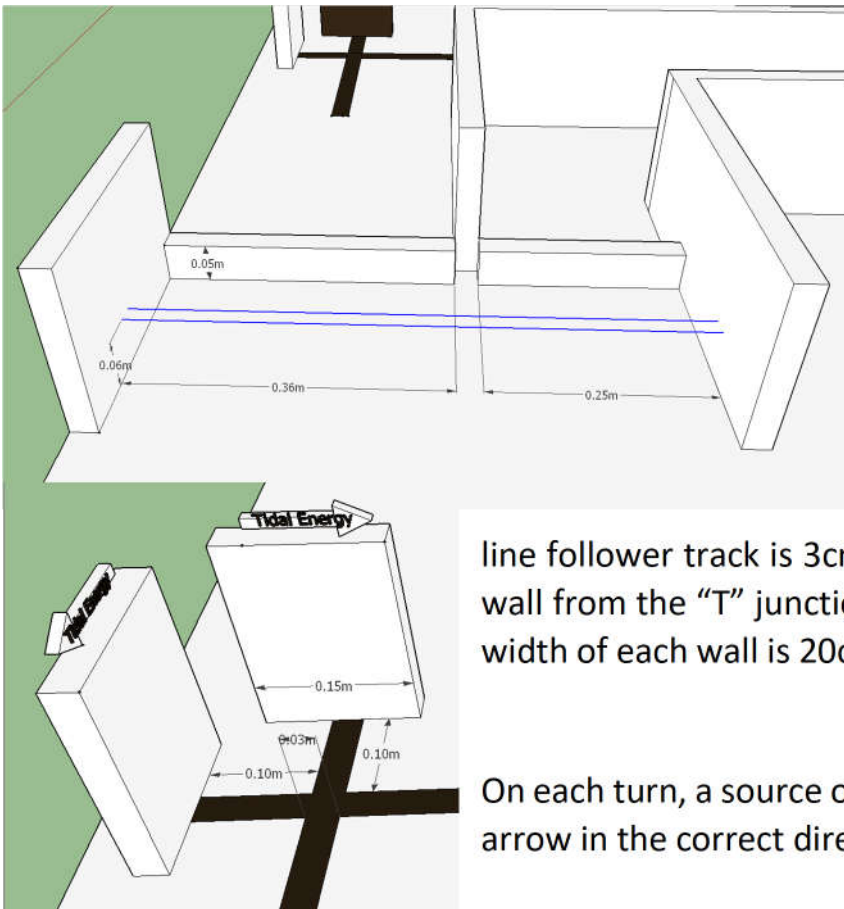

The width of the “Gate” to the “line follower track” is 36cm and the width of the gate to the “wall follower track” is 25cm. The laser beams are at a height of 6cm from the ground. The height of the gate is 5cm.

The width of each line in the line follower track is 3cm. The distance of the guiding wall from the “T” junction is 10cm and the height and width of each wall is 20cm and 15cm respectively.

On each turn, a source of renewable energy points the arrow in the correct direction.

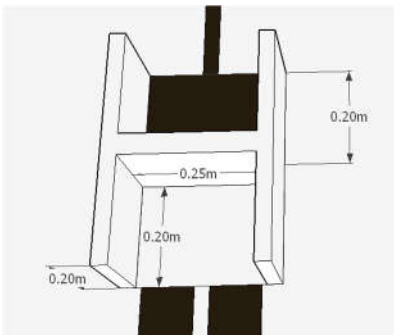

The 1st “H” junction/CHECKPOINT 1. The floor of each half of the “H” is 20cm long and 25cm wide. The colour floor on each side is same as the colour of the line on that side. The height of the wall is 20cm.

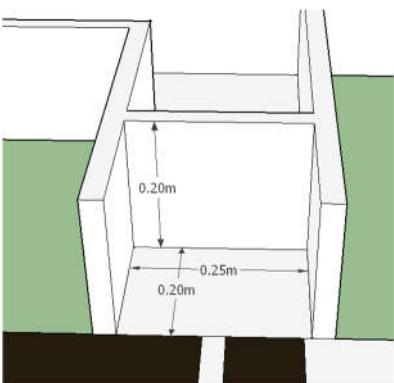

The 2nd “H” junction/CHECKPOINT 2.

The distance between two walls of the wall follower track is 25cm. The height of each wall is 20cm.

Arena*:

Prelims:

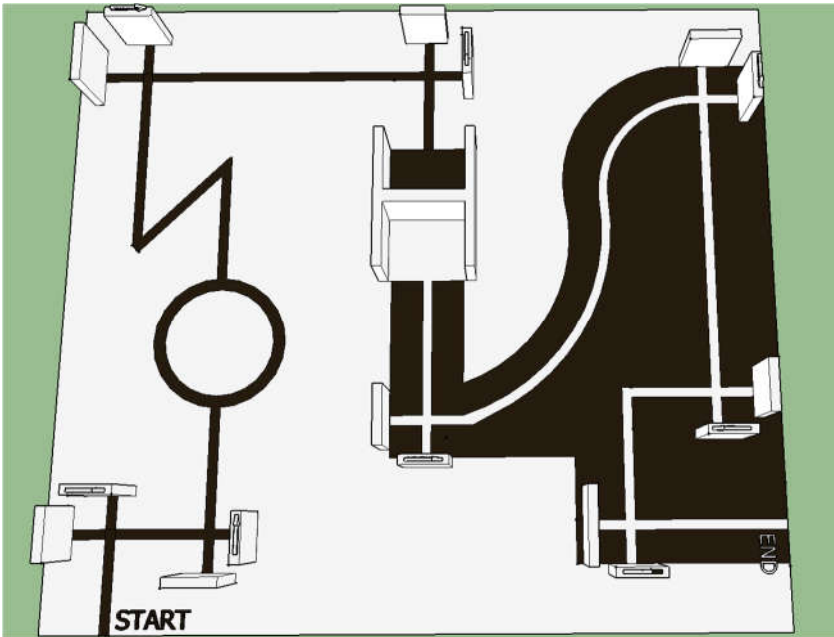
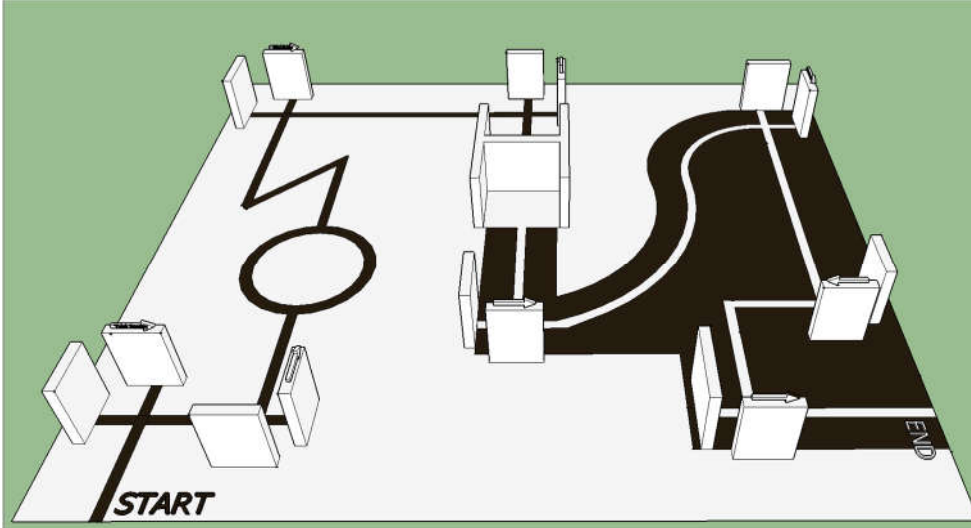

The total arena of the preliminary round is 2m x 2m in dimensions.

Finals:

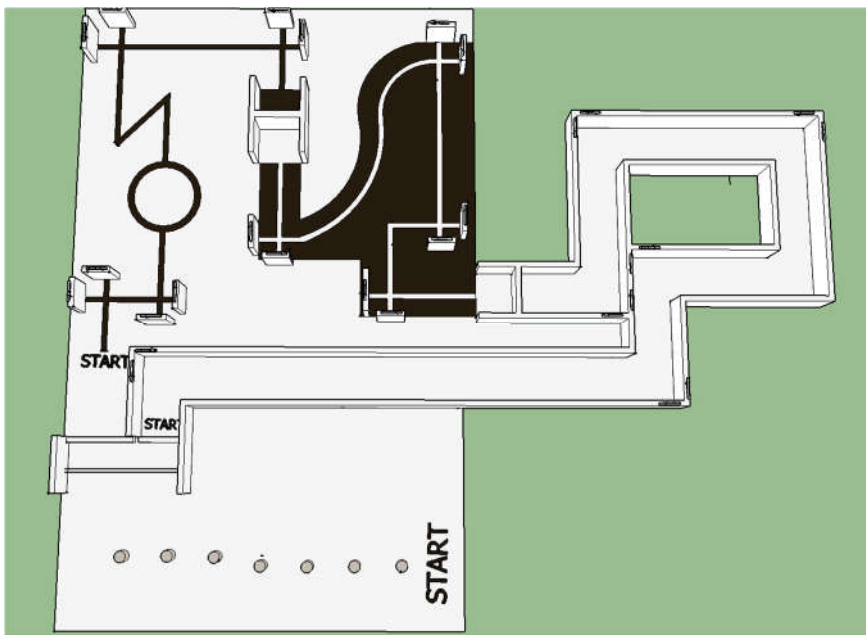
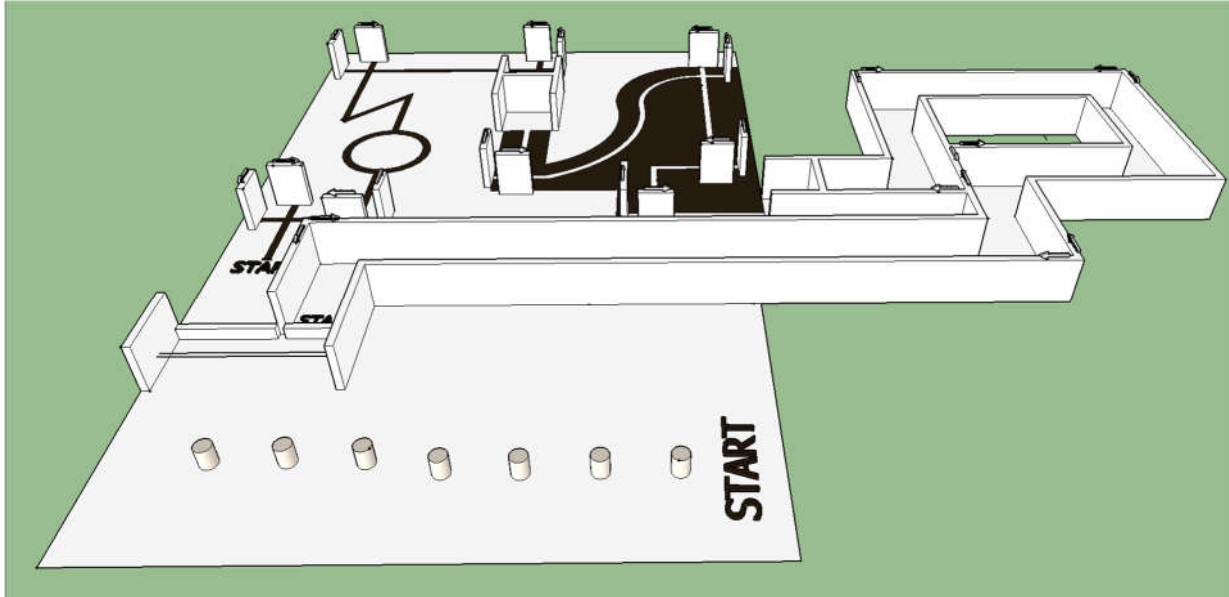

The total arena of the preliminary round is 3m x 3.5m in dimensions.

*This is the sample arena only for the rough idea of the participants. There will be changes in the layout of the final arena.



CEE



Specifications of the bot:

- A bot of any dimensions is allowed as long as it can go through the arena without destroying the arena.
- The bot can be semi-autonomous outside the line follower and the wall follower track, however, inside these two tracks the bot needs to be strictly autonomous.
- Fully autonomous bots are allowed too.

General Rules:

- Each team can have a maximum of five participants.
- Only a maximum of two participants are allowed to enter the arena during the game.
- Number of timeouts allowed per team: 2 in the preliminary round, 3 in the final round.
- Maximum time allowed per timeout: 60seconds.
- No harm is to be caused to the arena or to the other bots.
- The judges' decision is final and binding.

Scoring System:

- Each team is initially awarded with 500 points in the preliminary round and 1000 points in the final round.
- 50 points are deducted each time the bot deviates from the path, or touches the walls.
- 100 points are deducted if the participants want to skip any part of the track. However, 300 points are deducted if the participants want to skip the Semi-autonomous track.
- 100 points are deducted if the bot collides with any of the guiding walls in the line follower track.
- 50 points are deducted if the bot collides into one of the obstacles in the semi-autonomous track.
- 20 points are awarded each time the bot starts with a correct turn after the "T" joint in the line follower track.
- 400 points are awarded on each checkpoint if the checkpoint is detected and the bot starts with the next part of the track perfectly. However, if the





checkpoint is detected and the bot does NOT start again and/or deviates from the path just after starting, then, only 200 points are awarded to the team.

- 50 points are deducted each time a manual assistance is provided to the bot.
- 200 points are deducted from the 3rd timeout in the preliminary round and from the 4th timeout in the final round.

The final score of a team is the total number of the points scored minus the time taken for the completion of the event (in seconds).

The team will be disqualified if they fail to finish in the specified time limit.

The team will be disqualified if any harm is caused to the arena.

The team with the highest final score is the winner.

Certification policy and prizes

- Certificate of Excellence and Prizes worth 10k will be awarded to winners and runner-up.
- Certificate of Appreciation will be Awarded to 2nd runner-up.
- Certificate of Participation to all the teams participating in Event.

Contact Details:

Purnima - 8764242420

Pradum - 7979070927

Just in case you were wondering, “Arbitrium” is a Latin word which translates to “decision” or “choice”.

All the best for Aarohan!